

SERIE CG01 - CILINDRI CON GUIDA INTEGRATA

DOUBLE-ACTING MAGNETIC TWIN-GUIDE CYLINDERS
 ZYLINDER MIT INTEGRIERTER FÜHRUNG
 VÉRINS AVEC GUIDE INTÉGRÉ
 CILINDROS CON VÁSTAGOS PARALELOS DOBLE EFECTO MAGNETICO
 CILINDRO DUPLA AÇÃO MAGNÉTICO COM GUIA DUPLA



CARATTERISTICHE TECNICHE

TECHNICAL CHARACTERISTICS
 TECHNISCHE ANGABEN
 CARACTÉRISTIQUES TECHNIQUES
 CARACTERÍSTICAS TÉCNICAS
 CARACTERÍSTICAS TÉCNICAS



1907/2006

REACH

2011/65/CE

RoHS

Materiali	IT	Materials	GB	Materialien	DE
<ul style="list-style-type: none"> Corpo: Lega alluminio Piastra: Acciaio Stelo: Ø 12÷20 acciaio inox Ø 25÷63 Acciaio Magnete: Plastroferrite Guarnizioni: NBR Ammortizzatore: NBR 		<ul style="list-style-type: none"> Body: Aluminum alloy Plate: Carbon Steel Piston rod: Ø 12÷20 Stainless steel Ø 25÷63 Carbon Steel Magnet: Plastroferrite NBR seals Cushion: NBR 		<ul style="list-style-type: none"> Körper: Aluminium Legierung Platte: Stahl Kolbenstange: R 12÷20 Edelstahl R 25÷63 Stahl Magnet: Plastroferrit Dichtungen: NBR Stossdämpfer: NBR 	
Matériaux	FR	Materialies	ES	Materialis	PT
<ul style="list-style-type: none"> Corps : Alliage d'aluminium Plaque : Acier Tige : Ø 12÷20 acier inox Ø 25÷63 Acier Aimant : Plastroferrite Joints : NBR Amortissement : NBR 		<ul style="list-style-type: none"> Cuerpo: Aleación de aluminio Placa: Acero Vástago: Ø 12÷20 acero inox Ø 25÷63 Acero Magnete: Plastroferrita Juntas: NBR Amortiguación: NBR 		<ul style="list-style-type: none"> Corpo: Liga de alumínio Placa: Aço Haste: Ø 12÷20 aço inox Ø 25÷63 Aço Magnética: Plastroferrite Vedações: NBR Amortecimento: NBR 	



Pressioni

Pressures

Druckbereich

Pressions

Presiones

Pressões

1 bar (0.1 MPa)

10 bar (1 MPa)



Temperature

Temperatures

Temperatur

Températures

Temperaturas

Temperaturas

-5 °C (No freezing)

+ 60 °C



Fluidi compatibili

Aria (Lubrificazione non necessaria).

Fluids

Air (Lubrication not necessary).

Geeignete Medien

Luft (Schmierung nicht erforderlich).

Fluides compatibles

Air (Lubrification pas nécessaire).

Fluidos compatibles

Aire (Lubrificación no necesaria).

Fluidos compatíveis

Ar (Lubrificação não necessária).



Alesaggi

Bores

Durchmesser

Diamètres

Diámetros

Diâmetros

12-16-20-25-32-40-50-63 mm



Range velocità

Speed range

Verfügbarer Geschwindigkeitsbereich

Plage de vitesse disponible

Rango velocidad

Range de velocidades

50 mm/sec

500 mm/sec

Архангельск (8182)63-90-72
 Астана (7172)727-132
 Астрахань (8512)99-46-04
 Барнаул (3852)73-04-60
 Белгород (4722)40-23-64
 Брянск (4832)59-03-52
 Владивосток (423)249-28-31
 Волгоград (844)278-03-48
 Вологда (8172)26-41-59
 Воронеж (473)204-51-73
 Екатеринбург (343)384-55-89
 Иваново (4932)77-34-06

Ижевск (3412)26-03-58
 Иркутск (395)279-98-46
 Казань (843)206-01-48
 Калининград (4012)72-03-81
 Калуга (4842)92-23-67
 Кемерово (861)203-40-90
 Краснодар (861)203-40-90
 Киров (8332)68-02-04
 Красноярск (391)204-63-61
 Курск (4712)77-13-04
 Липецк (4742)52-20-81
 Киргизия (996)312-96-26-47

Магнитогорск (3519)55-03-13
 Москва (495)268-04-70
 Мурманск (8152)59-64-93
 Набережные Челны (8552)20-53-41
 Нижний Новгород (831)429-08-12
 Новокузнецк (3843)20-46-81
 Новосибирск (383)227-86-73
 Омск (3812)21-46-40
 Орел (4862)44-53-42
 Оренбург (3532)37-68-04
 Пенза (8412)22-31-16
 Казахстан (772)734-952-31

Пермь (342)205-81-47
 Ростов-на-Дону (863)308-18-15
 Рязань (4912)46-61-64
 Самара (846)206-03-16
 Санкт-Петербург (831)309-46-40
 Саратов (845)249-38-78
 Севастополь (8692)22-31-93
 Симферополь (3652)67-13-56
 Смоленск (4812)29-41-54
 Сочи (862)225-72-31
 Ставрополь (8652)20-65-13
 Таджикистан (992)427-82-92-69

Сургут (3462)77-98-35
 Тверь (4822)63-31-35
 Томск (3822)98-41-53
 Тула (4872)74-02-29
 Тюмень (3452)66-21-18
 Ульяновск (8422)24-23-59
 Уфа (347)229-48-12
 Хабаровск (4212)92-98-04
 Челябинск (351)202-03-61
 Череповец (8202)49-02-64
 Ярославль (4852)69-52-93



Peso cilindro

Cylinder Weight

Zylinder Gewicht

Poids du vérin

Peso Cilindro

Peso do Cilindro

Ø	Standard stroke (mm)	
	Basic weight	Stroke 5 mm
12	191	21
16	283	28
20	450	45
25	670	63
32	1.210	90
40	1.474	88
50	2.540	140
63	3.345	157

(Unit: g)



Sensori consigliati

Sensors recommended

Empfohlene Sensoren

Capteurs recommandés

Sensores recomendados

Sensores aconselhados

DC 01 RM8
DC 01 R2M

DC 03 PM8
DC 03 P2M

DC 04 PM8
DC 04 P2M



Tabella dei codici di ordinazione

Ordering codes

Bestellschlüssel

Code de commande

Tabla de codificación para pedidos

Tabela de codificação para compra

SERIE	Ø mm	Corsa Stroke Hub Course Carrera Curso mm
-------	---------	--

C G 0 1

0 1 2

0 0 1 0

012
016
020
025
032
040
050
063

0010
0020
0025
0030
0040
0050
0075
0100
0125
0150
0175
0200
0250
0300
0350
0400

A richiesta corse intermedie o superiori.
Intermediate or higher strokes are available upon request.
Auf Anfrage Zwischenhübe.
Autres courses sur demande.
Bajo demanda carreras intermedias o superiores.
Cursos intermedíarios ou superiores sob encomenda.

Ø mm																
	10	20	25	30	40	50	75	100	125	150	175	200	250	300	350	400
12	▲	▲		▲	▲	▲	▲	▲	▲	▲	▲	▲	▲			
16	▲	▲		▲	▲	▲	▲	▲	▲	▲	▲	▲	▲			
20		▲		▲	▲	▲	▲	▲	▲	▲	▲	▲	▲		▲	▲
25		▲		▲	▲	▲	▲	▲	▲	▲	▲	▲	▲	▲	▲	▲
32			▲			▲	▲	▲	▲	▲	▲	▲	▲	▲	▲	▲
40			▲			▲	▲	▲								
50			▲			▲	▲	▲								
63			▲			▲	▲	▲								

CG01 Ø 12 ÷ Ø 32

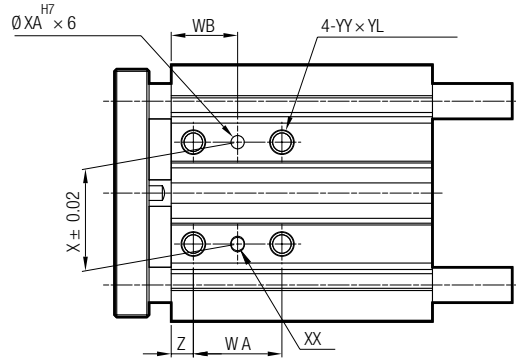

Back side

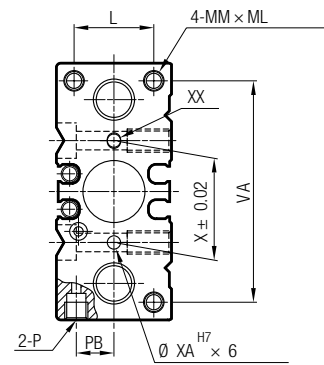
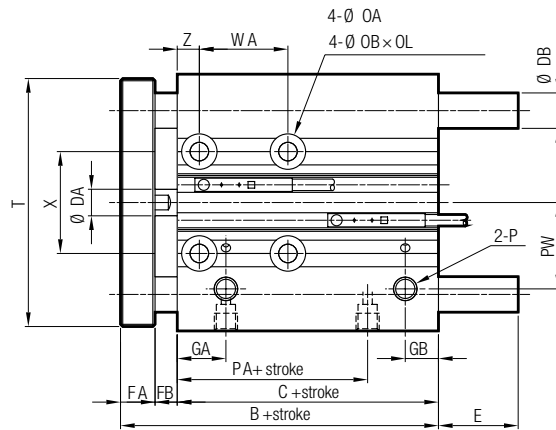
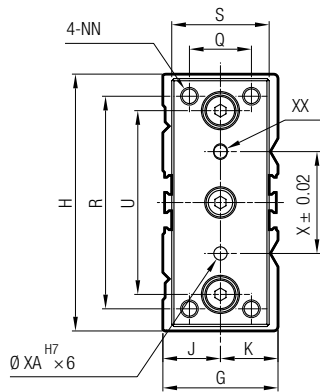
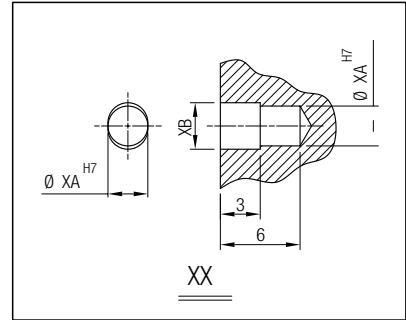

Ø	B	C	DA	DB	FA	FB	G	GA	GB	H	J	K	L	MM	ML	NN	OA	OB	OL
12	42	29	6	8	8	5	26	11	15*	58	13	13	18	M4 x 0,7	10	M4 x 0,7	4,3	8,0	4,5
16	46	33	8	10	8	5	30	11	18**	64	15	15	22	M5 x 0,8	12	M5 x 0,8	4,3	8,0	4,5
20	53	37	10	12	10	6	36	10,5	8,5	85	17	19	24	M5 x 0,8	13	M5 x 0,8	5,2	9,5	5,5
25	53,5	37,5	12	16	10	6	42	11,5	9	96	21	21	30	M6 x 1,0	15	M6 x 1,0	5,2	9,5	5,5
32	59,5	37,5	16	20	12	10	51	12,5	9	116	26	25	34	M8 x 1,25	20	M8 x 1,25	6,6	11,0	7,5

Ø	P	PA	PB	PW	Q	R	S	T	U	VA	X	XA	XB	YY	YL	Z	E		
																	st. 10-50	st. 51 - 100	st. 100+
12	M5 x 0,8	14	8,5	18	14	48	22	56	41,5	50	23	3	3,5	M5 x 0,8	10	5	-	18,5	43
16	M5 x 0,8	15	10,0	19	16	54	25	62	46	56	24	3	3,5	M5 x 0,8	10	5	-	18,5	49
20	G 1/8	12,5	11,5	25	18	70	30	81	55	72	28	3	3,5	M6 x 1,0	12	17	-	31,5	69
25	G 1/8	12,5	13,5	28,5	26	78	38	91	65	82	34	4	4,5	M6 x 1,0	12	17	-	31,5	68,5
32	G 1/8	7	16,0	34	30	96	44	110	80	98	42	4	4,5	M8 x 1,25	16	21	37,5	52,5	80,5

Ø	WA					WB				
	~39st	40~100st	125~200st	201~300st	301st~	20~39st	40~100st	125~200st	201~300st	301st
12	20	40	110	200	-	15	25	60	105	-
16	24	44	110	200	-	17	27	60	105	-
20	24	44	120	200	300	29	39	77	117	167
25	24	44	120	200	300	29	39	77	117	167
32	24	48	124	200	300	33	45	83	121	171

* Quando la lunghezza della corsa è pari a 19mm o inferiore, GB=7,5mm
 When stroke length is equal to 19 mm or less, GB=7,5 mm
 Wenn Hublänge gleich 19 mm oder weniger, GB=7,5 mm
 Lorsque la longueur de la course est égale ou inférieure à 19mm, GB=7,5mm
 Cuando la longitud de la carrera es igual a 19 mm o menor, GB=7,5 mm
 Quando o curso do cilindro é igual ou inferior a 19mm, GB=7,5mm

** Quando la lunghezza della corsa è pari a 19mm o inferiore, GB=9mm
 When stroke length is equal to 19 mm or less, GB=9 mm
 Wenn Hublänge gleich 19 mm oder weniger, GB=9mm
 Lorsque la longueur de la course est égale ou inférieure à 19mm, GB=9mm
 Cuando la longitud de la carrera es igual a 19 mm o menor, GB=9 mm
 Quando o curso do cilindro é igual ou inferior a 19mm, GB = 9mm

CG01 Ø 40 ÷ Ø 63

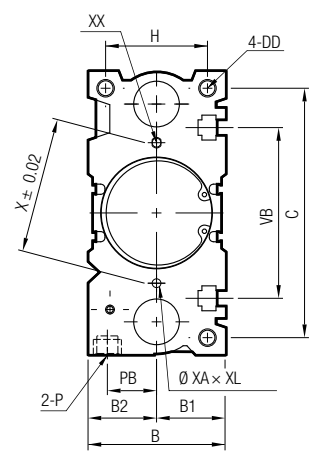
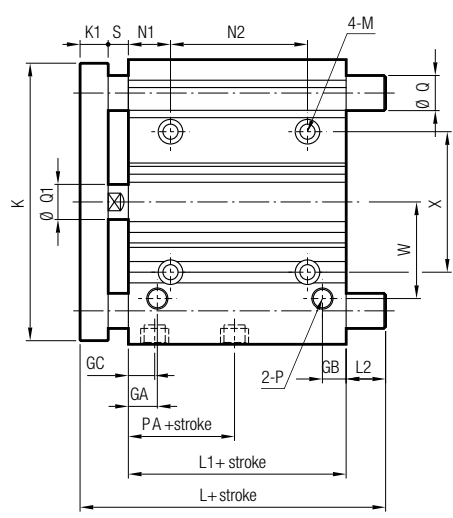
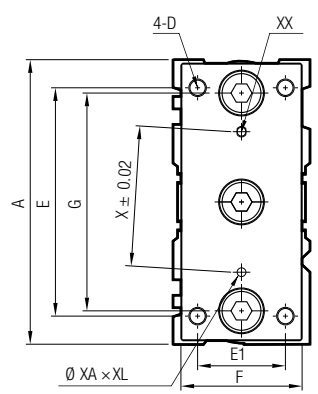
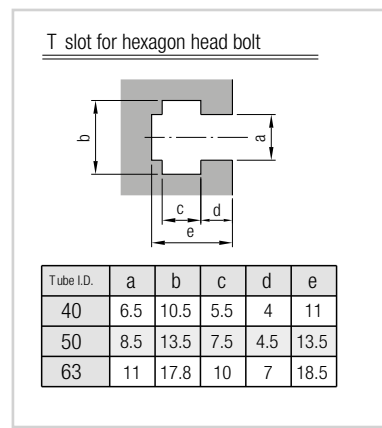
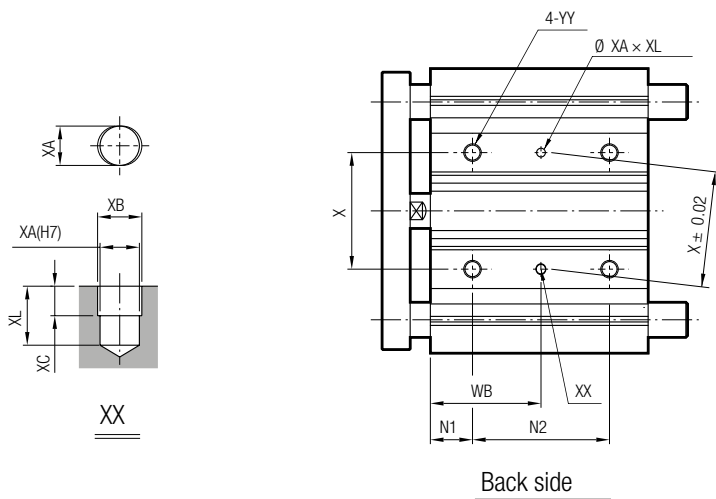

Ø	A	B	B1	B2	C	D	DD	E	E1	F	G	GA	GB	GC	H	K	K1	L1	M
40	120	54	27	27	106	M8x1,25	M8x1,25x20	104	30	44	86	14	10	14	40	118	12	44	ø6,6 - ø11x7,5
50	148	64	32	32	130	M10x1,5	M10x1,5x22	130	40	60	110	14	11	12	46	146	16	44	ø8,6 - ø14x9
63	162	78	39	39	142	M10x1,5	M10x1,5x22	130	50	70	124	16,5	13,5	16,5	58	158	16	49	ø8,6 - ø14x9

Ø	N1	P	PA	PB	Q1	S	VB	W	X	XA ^{H7}	XB	XC	XL	YY	N2			WB		
															25st	50-75-100 st	100st~	25st	50-75-100 st	100st~
40	22	G 1/8	13	18	16	10	72	38	50	4	4,5	3	6	M8x1,25x16	24	48	124	34	46	84
50	24	G 1/4	9	21,5	20	12	92	47	66	5	6	4	8	M10x1,5x20	24	48	124	36	48	86
63	24	G 1/4	14	28	20	12	110	55	80	5	6	4	8	M10x1,5x20	28	52	128	38	50	88

Ø	L		L2		Q
	25-50st	50st~	25-50st	50st~	
40	97	102	31	36	ø20
50	106,5	118	34,5	46	ø25
63	106,5	118	29,5	41	ø25



FORZE E CONSUMI

FORCES AND CONSUMPTIONS
KRÄFTE UND LUFTVERBRAUCH
FORCES ET CONSOMMATIONS D'AIR
FUERZAS Y CONSUMOS
FORÇAS E CONSUMOS

Forze di spinta e tiro - Thrust and traction forces - Schub-und zugkräfte - Force de poussée et de traction - Fuerza de empuje y tracción - Força de avanço e recuo.

Ø Cilindro Cylinder Zylinder Vérins Cilindro Cilindro	Ø Stelo Rod Stange Tige Vástago Haste	Superficie spinta Pushing surface Schubfläche Surface de poussée Superficie de empuje Area de avanço	Superficie trazione Traction surface Zugfläche Surface de traction Superficie de tracción Area de retorno	Pressione di lavoro Operating pressure Betriebsdruck Pression de service Presión de trabajo Pressão de operação									
				bar									
mm	mm	mm ²	mm ²	1	2	3	4	5	6	7	8	9	10
				Forza sviluppata Output force Zylinderkraft Force du vérin Fuerza desarrollada Força desenvolvida N									
12	6	113,04	84,78	S = 10	20	30	40	50	59,9	69,9	79,8	89,8	99,8
				T = 7,5	15	22,5	30	37,5	44,9	52,4	59,9	67,4	74,9
16	8	200,96	150,72	S = 17,7	35,5	53	71	88,7	106,5	124	141,9	159,7	177,4
				T = 13,3	26,6	39,9	53,2	66,5	79,8	93	106,5	119,7	133
20	10	314,00	235,50	S = 27,7	55,4	83,1	110,9	138,6	166,3	194	221,8	249,5	277,23
				T = 20,8	41,6	62,4	83,2	104	124,8	145,5	166,3	187,1	207,9
25	12	490,62	377,58	S = 43,3	86,6	130	173,3	216,6	259,9	303,2	346,5	389,8	433,1
				T = 33,3	66,7	100	133,3	166,7	200	233,3	266,7	300	333,4
32	16	803,84	602,88	S = 71	141,9	212,9	283,8	354,9	425,8	496,8	567,8	638,7	709,7
				T = 53,2	106,5	159,7	212,9	266,1	319,4	372,6	425,8	479	532,2
40	16	1256,00	1055,04	S = 110,9	221,8	332,6	443,5	554,5	665,4	776,2	887,1	998	1108,9
				T = 93,1	186,3	279,4	372,6	465,7	558,9	652	745,2	838,3	931,5
50	20	1962,50	1648,50	S = 173,3	346,5	519,8	693	866,3	1039,6	1212,9	1386,1	1559,4	1732,7
				T = 145,5	291	436,6	582,1	727,7	873,2	1018,8	1164,4	1310	1455,5
63	20	3115,66	2801,66	S = 275,1	550,1	825,2	1100,3	1375,4	1650,5	1925,6	2200,6	2475,7	2750,8
				T = 247,4	494,7	742	989,4	1236,8	1484,1	1731,5	1978,9	2226,2	2473,6

S Spinta - Thrust - Schub - Poussée - Empuje - Avanço
T Trazione - Traction - Zugkraft - Traccion - Tracción - Recuo

Consumi cilindro - Cylinder air consumption - Zylinder Luftverbrauch - Consommation d'air des vérins - Consumo cilindro - Consumo de ar do cilindro.

Ø Cilindro Cylinder Zylinder Vérins Cilindro Cilindro	Ø Stelo Rod Stange Tige Vástago Haste	Superficie spinta Pushing surface Schubfläche Surface de poussée Superficie de empuje Area de avanço	Superficie trazione Traction surface Zugfläche Surface de traction Superficie de tracción Area de retorno	Pressione di lavoro Operating pressure Betriebsdruck Pression de service Presión de trabajo Pressão de operação									
				bar									
mm	mm	mm ²	mm ²	1	2	3	4	5	6	7	8	9	10
				Consumo aria per ogni 10 mm di corsa Air consumption for each 10 mm of stroke Luftverbrauch pro 10 mm Hub Consommation d'air par 10 mm de course Consumo aire para cada 10 mm de carrera Consumo de ar para cada 10 mm de curso NL									
12	6	113,04	84,78	S = 0,00226	0,00452	0,00678	0,00904	0,01130	0,01356	0,01583	0,01809	0,02035	0,02261
				T = 0,00170	0,00339	0,00509	0,00678	0,00848	0,01017	0,01187	0,01356	0,01526	0,01696
16	8	200,96	150,72	S = 0,00402	0,00804	0,01206	0,01608	0,02010	0,02412	0,02813	0,03215	0,03617	0,04019
				T = 0,00301	0,00603	0,00904	0,01206	0,01507	0,01809	0,02110	0,02412	0,02713	0,03014
20	10	314,00	235,50	S = 0,00628	0,01256	0,01884	0,02512	0,03140	0,03768	0,04396	0,05024	0,05652	0,06280
				T = 0,00471	0,00942	0,01413	0,01884	0,02355	0,02826	0,03297	0,03768	0,04239	0,04710
25	12	490,62	377,58	S = 0,00981	0,01963	0,02944	0,03925	0,04906	0,05888	0,06869	0,07850	0,08831	0,09813
				T = 0,00755	0,01510	0,02266	0,03021	0,03776	0,04531	0,05286	0,06041	0,06797	0,07552
32	16	803,84	602,88	S = 0,01608	0,03215	0,04823	0,06431	0,08038	0,09646	0,11254	0,12861	0,14469	0,16077
				T = 0,01206	0,02412	0,03617	0,04823	0,06029	0,07235	0,08440	0,09646	0,10852	0,12058
40	16	1256,00	1055,04	S = 0,02512	0,05024	0,07536	0,10048	0,12560	0,15072	0,17584	0,20096	0,22608	0,25120
				T = 0,02110	0,04220	0,06330	0,08440	0,10550	0,12660	0,14771	0,16881	0,18991	0,21101
50	20	1962,50	1648,50	S = 0,03925	0,07850	0,11775	0,15700	0,19625	0,23550	0,27475	0,31400	0,35325	0,39250
				T = 0,03297	0,06594	0,09891	0,13188	0,16485	0,19782	0,23079	0,26376	0,29673	0,32970
63	20	3115,66	2801,66	S = 0,06231	0,12463	0,18694	0,24925	0,31157	0,37388	0,43619	0,49851	0,56082	0,62313
				T = 0,05603	0,11207	0,16810	0,22413	0,28017	0,33620	0,39223	0,44827	0,50430	0,56033

S Spinta - Thrust - Schub - Poussée - Empuje - Avanço
T Trazione - Traction - Zugkraft - Traccion - Tracción - Recuo

CARICO MASSIMO LATERALE AMMISSIBILE DI LAVORO

ALLOWABLE LATERAL LOAD
 MAXIMAL ZULAESSIGE HORIZONTAL EN KRAEFTE
 CHARGE MAXIMALE LATERALE DE TRAVAIL ADMISSIBLE
 CARGA MÁXIMA LATERAL ADMISIBLE DE TRABAJO
 CARGA MÁXIMA LATERAL ADMISSÍVEL

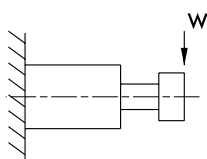

Ø	Stroke (mm)															
	10	20	25	30	40	50	75	100	125	150	175	200	250	300	350	400
12	31	24	-	19	16	13	37	31	15	13	12	10	9	-	-	-
16	50	39	-	32	27	24	54	45	27	24	21	19	16	-	-	-
20	-	51	-	44	39	35	54	46	74	66	59	54	28	24	21	19
25	-	68	-	59	52	46	72	61	98	88	79	72	53	46	41	37
32	-	-	165	-	-	129	106	90	138	123	111	101	88	77	68	61

(Unit: N)

COPPIA MASSIMA AMMISSIBILE DI ROTAZIONE

ALLOWABLE ROTATING TORQUE
 MAXIMAL ZULAESSIGE ROTATIONS KRAEFTE
 COUPLE MAXIMUM DE ROTATION ADMISSIBLE
 PAR DE ROTACIÓN MÁXIMO ADMISIBLE
 TORQUE DE ROTAÇÃO ADMISSÍVEL

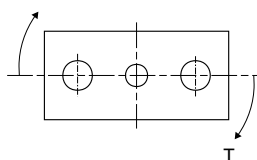

Ø	Stroke (mm)															
	10	20	25	30	40	50	75	100	125	150	175	200	250	300	350	400
12	0,64	0,48	-	0,39	0,32	0,28	0,75	0,63	0,15	0,13	0,12	0,11	0,09	-	-	-
16	1,14	0,9	-	0,74	0,63	0,55	1,23	1,04	0,31	0,27	0,24	0,22	0,18	-	-	-
20	-	1,14	-	1,21	1,07	0,95	1,49	1,25	2,03	1,81	1,63	1,48	0,37	0,32	0,29	0,26
25	-	2,19	-	1,88	1,65	1,47	2,31	1,94	3,15	2,8	2,52	2,3	0,85	0,74	0,66	0,59
32	-	-	6,61	-	-	5,16	4,23	3,59	5,52	4,93	4,45	4,06	1,72	1,50	1,33	1,20

(Unit: N·m)



Scostamento angolare

Anti-roll accuracy

Winkelabweichung

Ecartement angulaire

Desviación angular

Precisão angular anti-giro

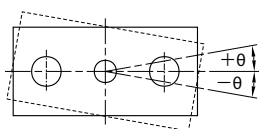

Ø	Scostamento angolare Anti-roll Accuracy Ecartement angulaire Winkelabweichung Desviación angular Precisão angular anti-giro θ
	12
16	± 0,08°
20	± 0,08°
25	± 0,07°
32	± 0,07°



Grafico per utilizzo come fermo

Graph for the use as a stopper (Ø 12 ÷ 32)

Diagramm für die Verwendung als STOPPER (R12 – 32)

Graphique pour utiliser le vérin en tant que butée

Gráfico para el uso como parado (Ø 12 ÷ 32)

Gráfico para utilização como stopper (Ø 12 ÷ 32)

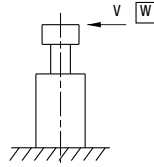

CAPACITÀ DI FERMO

STOP CAPACITY
STOPP KAPAZITÄT
CAPACITE D'ARRÊT
CAPACIDAD DE PARADA
CAPACIDADE DE PARADA

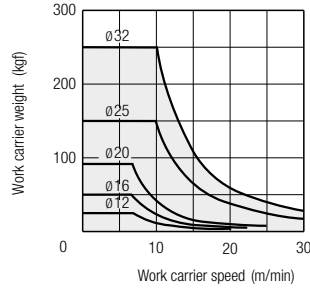

CARICO LATERALE

LATERAL LOAD
NORMALE SEITENKRAEFTE
CHARGE LATÉRALE
CARGA LATERAL
CARGA LATERAL

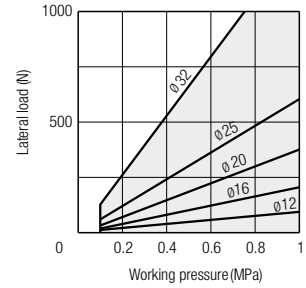

COEFFICIENTE DI CONVERSIONE

COEFFICIENTS FOR CONVERSION
UMRECHNUNGSKOEFFIZIENTEN
COEFFICIENTS DE CONVERSION
COEFICIENTE DE CONVERSIÓN
COEFICIENTE DE CONVERSÃO

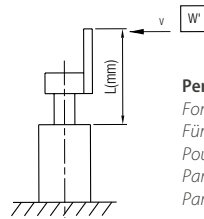

Per attaccare una piastra alla barra di collegamento, scegliere un diametro secondo la formula.

For the use of attaching a plate to the link bar, choose a bore size referring to the formula.

Für die Befestigung einer Platte an die Verbindungsstange, nehmen Sie für die Bohrdurchmesser Bezug auf die Formel.

Pour la fixation d'une plaque à la barre de liaison, choisissez un diamètre suivant la formule.

Para la fijación de una placa sobre la barra, escoger un diámetro referido a la fórmula.

Para aplicações com placas fixadas no cilindro, escolha o diâmetro de acordo com a fórmula.

SERIES	Ø 12	Ø 16	Ø 20	Ø 25	Ø 32
l	40	42	42	42	44

$$W^1 = \frac{W \cdot l}{L}$$

W: Peso massimo di lavoro come da grafico per la funzione di bloccaggio.

W: The maximum weight of the working load in the above graph for the stopper's capacity.

W: Höchstarbeitsgewicht gemäss Diagramm für die Verriegelungsfunktion

W: Charge maximale de travail donnée dans le graphique ci dessus pour la fonction de verrouillage.

W: Peso máximo para el trabajo realizado en el gráfico superior para la capacidad de paro.

W: Peso máximo da carga de trabalho no gráfico acima para a capacidade do stopper



Grafico utilizzo sollevamento

Capacity graph for the use as a LIFTER

Diagramm für die Verwendung als HEBER

Graphique pour utilisation de levage

Gráfico para el uso como elevador

Gráfico para uso como Lifter (levantamento de cargas)

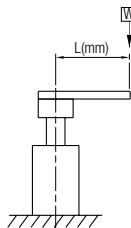

Carico di eccentricità consentito per uso sollevamento alla pressione di 5 bar. Mostra il valore consentito dinamico a L (mm) dal centro della guida.

Allowable eccentricity load for the use as a lifter at supply pressure 5 bar.

Show the dynamic allowable value at L (mm) from the centre of the guide rod.

Zulässige Exzentrizitäts-Last für die Verwendung als Heber bei 5 bar Betriebsdruck.

Zeigt den dynamisch zulässigen Wert bei L (mm) von der Mitte der Führungsstange

Charge excentrée autorisée pour l'utilisation de levage à la pression de 5 bar.

Montrez la valeur dynamique autorisée à L (mm) à partir du centre de guidage.

Carga de excentricidad permitida para el uso como elevador a presión de 5 bar

Muestra el valor dinámico permisible a L (mm) desde el centro del eje de guía.

Distância máxima da carga com relação ao centro do cilindro para aplicações como lifter com pressão de alimentação de 5 bar.

Ver o valor permitido dinâmico em L (mm) a partir do centro da barra de guia.

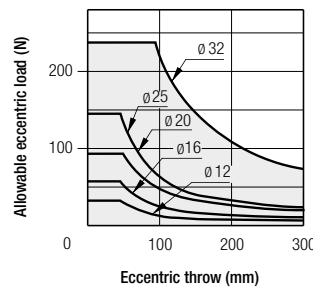

Cuscinetto scorrimento 10-50 st

Slide Bearing 10-50 st

Gleitlager 10-50 st

Guide lisse 10-50 st

Cojinete 10-50 st

Deslizamento por esfera 10-50 st

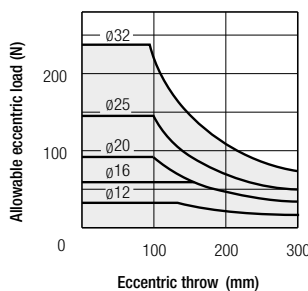

Cuscinetto scorrimento superiore a 51 st

Slide Bearing over 51 st

Gleitlager über 51 st

Guide lisse au delà de 51 st

Cojinete superior 51 st

Deslizamento por esfera 51 st

SERIE CG02 - CILINDRI DOPPIO EFFETTO MAGNETICO GUIDATO

DOUBLE ACTING MAGNETIC DUAL-ROD CYLINDER
 ZYLINDER DOPPELTWIRKEND MAGNETISCH GEFÜHRT
 VÉRIN GUIDÉ DOUBLE EFFET MAGNÉTIQUE
 CILINDROS COMPACTOS GUIADOS DOBLE EFECTO MAGNÉTICO
 CILINDROS DUPLA AÇÃO MAGNÉTICO COM HASTE DUPLA



CARATTERISTICHE TECNICHE
 TECHNICAL CHARACTERISTICS
 TECHNISCHE ANGABEN
 CARACTÉRISTIQUES TECHNIQUES
 CARACTERÍSTICAS TÉCNICAS
 CARACTERÍSTICAS TÉCNICAS



1907/2006
REACH ✓

2011/65/CE
RoHS ✓

Materiali	IT	Materials	GB	Materialien	DE
<ul style="list-style-type: none"> Corpo: Lega alluminio Piastra: Acciaio Stelo: Ø 12÷20 acciaio inox Ø 32 Acciaio Magnete: Plastroferrite Guarnizioni: NBR Ammortizzatore: NBR 		<ul style="list-style-type: none"> Body: Aluminum alloy Plate: Carbon Steel Piston rod: Ø 12÷20 Stainless steel Ø 32 Carbon Steel Magnet: Plastroferrite NBR seals Cushion: NBR 		<ul style="list-style-type: none"> Körper: Aluminium Legierung Platte: Stahl Kolbenstange: R 12÷20 Edelstahl R 32 Stahl Magnet: Plastroferrit Dichtungen: NBR Stossdämpfer: NBR 	
Matériaux	FR	Materiales	ES	Materiais	PT
<ul style="list-style-type: none"> Corps : Alliage d'aluminium Plaque : Acier Tige : Ø 12÷20 acier inox Ø 32 Acier Aimant : Plastroferrite Joints : NBR Amortissement : NBR 		<ul style="list-style-type: none"> Cuerpo: Aleación de aluminio Placa: Acero Vástago: Ø 12÷20 acero inox Ø 32 acero Magnete: Plastroferrita Juntas: NBR Amortiguación: NBR 		<ul style="list-style-type: none"> Corpo: Liga de alumínio Placa: Aço Haste: Ø 12÷20 aço inox Ø 32 aço Magnético: Plastroferrite Vedações: NBR Amortecimento: NBR 	



Pressioni

Pressures

Druckbereich

Pressions

Presiones

Pressões

Ø	6	12	16	20	25	32
min	1,5	1			0,5	
max			7			



Temperature

Temperatures

Temperatur

Temperatures

Temperaturas

Temperaturas

-5 °C (No freezing)
 + 60 °C



Fluidi compatibili

Aria (Lubrificazione non necessaria).

Fluids

Air (Lubrication not necessary).

Geeignete Medien

Luft (Schmierung nicht erforderlich).

Fluides compatibles

Air (Lubrification pas nécessaire).

Fluidos compatibles

Aire (Lubrificação no necesaria).

Fluidos compatíveis

Ar (Lubrificação não necessária).



Alesaggi

Bores

Durchmesser

Diamètres

Diámetros

Diâmetros

6-12-16-20-25-32 mm



Range velocità

Speed range

Verfügbarer Geschwindigkeitsbereich

Plage de vitesse disponible

Rango velocidad

Range de velocidades

Ø	6	12	16	20	25	32
	50÷300			50÷500		

(Unit: mm/sec)



Tipo di montaggio

Mounting Type

Montageart

Type de montage

Tipo de montaje

Tipo de montagem

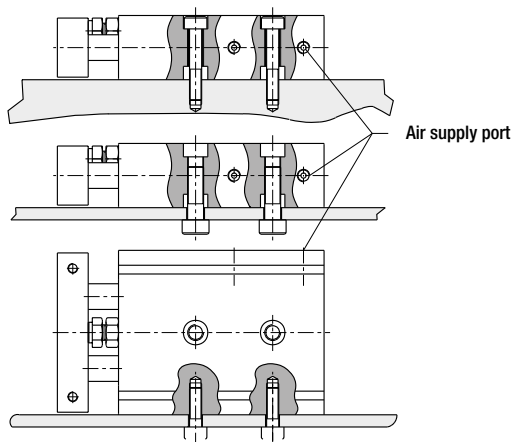

Sensori consigliati

Sensors recommended

Empfohlene Sensoren

Capteurs recommandés

Sensores recomendados

Sensores aconselhados

DC 01 RM8
DC 01 R2M

DC 03 PM8
DC 03 P2M

DC 04 PM8
DC 04 P2M



Scostamento angolare

Anti-roll accuracy

Winkelabweichung

Ecartement angulaire

Desviación angular

Precisão angular anti-giro

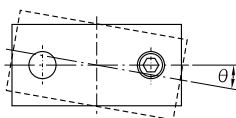

± 0,1°



Tabella dei codici di ordinazione

Ordering codes

Bestellschlüssel

Code de commande

Tabla de codificación para pedidos

Tabela de codificação para compra

SERIE	Ø mm	Corsa Stroke Hub Course Carrera Curso mm
-------	---------	--

C G 0 2 **0 0 6** **0 0 1 0**

006	0010
012	0020
016	0030
020	0040
025	0050
032	0060
	0070
	0080
	0090
	0100

A richiesta corse intermedie o superiori.
Intermediate or higher strokes are available upon request.
Auf Anfrage Zwischenhübe.
Autres courses sur demande.
Bajo demanda carreras intermedias o superiores.
Cursos intermedios ou superiores sob encomenda.

Ø mm	Corse - Strokes - Hub - Courses - Carreras - Cursos mm									
	10	20	30	40	50	60	70	80	90	100
6	▲	▲	▲							
12	▲	▲	▲	▲	▲	▲	▲			
16	▲	▲	▲	▲	▲	▲	▲	▲	▲	▲
20	▲	▲	▲	▲	▲	▲	▲	▲	▲	▲
25	▲	▲	▲	▲	▲	▲	▲	▲	▲	▲
32	▲	▲	▲	▲	▲	▲	▲	▲	▲	▲

CG02 Ø 6 ÷ Ø 32

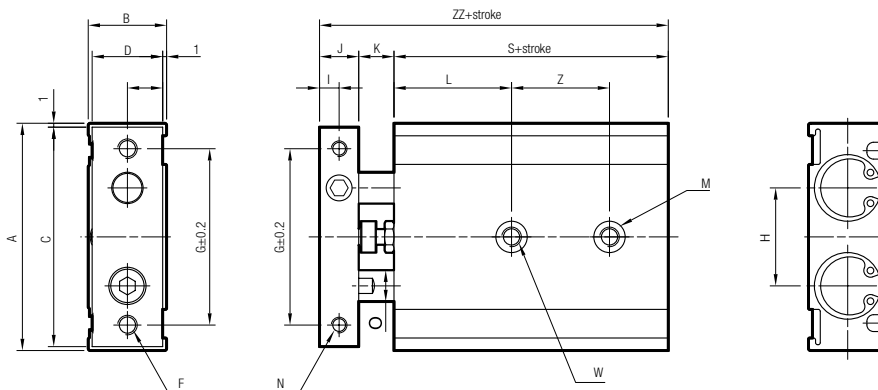

Ø 12 - 16

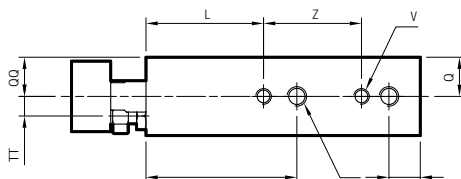

Ø 20 ÷ 32

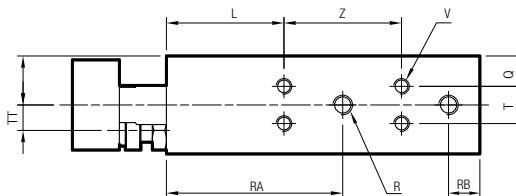

Ø 6

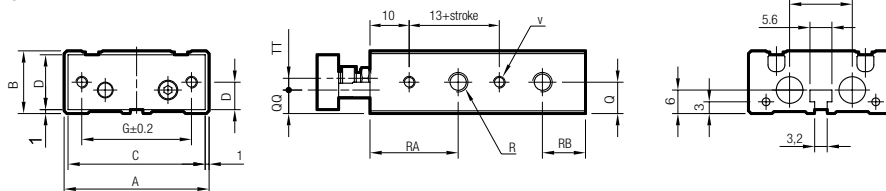

Ø	A	B	C	D	E	F (Thru)	G	H	I	J	K	L	M (both side)	N (both side)	O	Q	QQ	R (both side)
6	37	16	35	14	7	2-M3x0,5	28	16	2,75	5,5	8	13	2-ø6,5x3,3*	2-M3x0,5	4	8	6	4-M5x0,8
12	46	18	44	16	8	2-M4x0,7	35	19	4	8	9	20	4-ø6,5x3,3	4-M3x0,5x5	6	9	10	4-M5x0,8
16	58	20	56	18	9	2-M5x0,8	45	25	5	10	9	30	4-ø8x4,4	4-M4x0,7x6	8	10	10	4-M5x0,8
20	64	25	62	23	11,5	2-M5x0,8	50	28	6	12	12	30	4-ø9,5x5,3	4-M4x0,7x6	10	7,75	12,5	4-M5x0,8
25	80	30	78	28	14	2-M6x1,0	60	35	6	12	12	30	4-ø11x6,3	4-M5x0,8x8	12	8,5	15	4-G1/8
32	98	38	96	36	18	2-M6x1,0	75	44	8	16	14	30	4-ø11x6,3	4-M5x0,8x8	16	9	19	4-G1/8

Ø	RA	RB	S	T	TT	V (both side)	W (Thru)	Z (stroke)				ZZ
								10-15-20-25	30-35-40-45-50	60-70-75	80 90-100	
6	22,5	11	45	-	3	4-M3x0,5x4,5	2-ø3,4	10+1/2 Stroke**				58,8
12	30	8	55	-	3,5	4-M3x0,5x4,5	2-M4x0,7	30	40	50	-	72
16	38,5	8	60	-	5	4-M4x0,7x5	2-M5x0,8	25	35	45	55	79
20	45	8	70	9,5	6,5	8-M4x0,7x5,5	2-M6x1,0	30	40	60		94
25	46	9	72	13	9	8-M5x0,8x7,5	2-M8x1,25	30	40	60		96
32	56	10	82	20	11,5	8-M5x0,8x7,5	2-M8x1,25	40	50	70		112

* Ø 6 - solo da un lato
 Ø 6 - single side
 Ø 6 - Einseitig
 Ø 6 - un seul coté
 Ø 6 - solo de un lado
 Ø 6 - somente de um lado

** Ø 6 - corsa (10-20-30)
 Ø 6 - stroke (10-20-30)
 Ø 6 - Hub (10-20-30)
 Ø 6 - course (10-20-30)
 Ø 6 - carrera (10-20-30)
 Ø 6 - curso (10-20-30)

**FORZE E CONSUMI**

FORCES AND CONSUMPTIONS
 KRÄFTE UND LUFTVERBRAUCH
 FORCES ET CONSOMMATIONS D'AIR
 FUERZAS Y CONSUMOS
 FORÇAS E CONSUMOS

Forze di spinta e tiro - Thrust and traction forces - Schub-und zugkräfte - Force de poussée et de traction - Fuerza de empuje y tracción - Força de avanço e recuo.

Ø Cilindro Cylinder Zylinder Vérins Cilindro Cilindro	Ø Stelo Rod Stange Tige Vástago Haste	Superficie spinta Pushing surface Schubfläche Surface de poussée Superficie de empuje Área de avanço	Superficie trazione Traction surface Zugfläche Surface de traction Superficie de tracción Área de retorno	Pressione di lavoro Operating pressure Betriebsdruck Pression de service Presión de trabajo Pressão de operação	bar									
mm	mm	mm ²	mm ²											
				Forza sviluppata Output force Zylinderkraft Force du vérin Fuerza desarrollada Força desenvolvida N										
				1	2	3	4	5	6	7	8	9	10	
6	4	56,52	31,40	S =	5,00	10,00	15,00	20,00	25,00	29,90	34,90	39,90	44,90	49,90
				T =	2,80	5,50	8,30	11,00	13,90	16,60	19,40	22,20	25,00	27,70
12	6	226,08	169,56	S =	20,00	40,00	60,00	80,00	100,00	119,80	139,80	159,60	179,60	199,60
				T =	15,00	30,00	45,00	60,00	75,00	89,80	104,80	119,80	134,80	149,80
16	8	401,92	301,44	S =	35,40	71,00	106,00	142,00	177,40	213,00	248,00	283,80	319,40	354,80
				T =	26,60	53,20	79,80	106,40	133,00	159,60	186,00	213,00	239,40	266,00
20	10	628,00	471,00	S =	55,40	110,80	166,20	221,80	277,20	332,60	388,00	443,60	499,00	554,40
				T =	41,60	83,20	124,80	166,40	208,00	249,60	291,00	332,60	374,20	415,80
25	12	981,25	755,17	S =	86,60	173,20	260,00	346,60	433,20	519,80	606,40	693,00	779,60	866,20
				T =	66,60	133,40	200,00	266,60	333,40	400,00	466,60	533,40	600,00	666,80
32	16	1607,68	1205,76	S =	142,00	283,80	425,80	567,60	709,80	851,60	993,60	1135,60	1277,40	1419,40
				T =	106,40	213,00	319,40	425,80	532,20	638,80	745,20	851,60	958,00	1064,40

S Spinta
Thrust
Schub
Poussée
Empuje
Avanço

T Trazione
Traction
Zugkraft
Traction
Tracción
Recuo

Consumi cilindro - Cylinder air consumption - Zylinder Luftverbrauch - Consommation d'air des vérins - Consumo cilindro - Consumo de ar do cilindro.

Ø Cilindro Cylinder Zylinder Vérins Cilindro Cilindro	Ø Stelo Rod Stange Tige Vástago Haste	Superficie spinta Pushing surface Schubfläche Surface de poussée Superficie de empuje Área de avanço	Superficie trazione Traction surface Zugfläche Surface de traction Superficie de tracción Área de retorno	Pressione di lavoro Operating pressure Betriebsdruck Pression de service Presión de trabajo Pressão de operação	bar									
mm	mm	mm ²	mm ²											
				Consumo aria per ogni 10 mm di corsa Air consumption for each 10 mm of stroke Luftverbrauch pro 10 mm Hub Consommation d'air par 10 mm de course Consumo aire para cada 10 mm de carrera Consumo de ar para cada 10 mm de curso NL										
				1	2	3	4	5	6	7	8	9	10	
6	4	56,52	31,40	S =	0,0011	0,0023	0,0034	0,0045	0,0057	0,0068	0,0079	0,0090	0,0102	0,0113
				T =	0,0006	0,0013	0,0019	0,0025	0,0031	0,0038	0,0044	0,0050	0,0057	0,0063
12	6	226,08	169,56	S =	0,0045	0,0090	0,0136	0,0181	0,0226	0,0271	0,0317	0,0362	0,0407	0,0452
				T =	0,0034	0,0068	0,0102	0,0136	0,0170	0,0203	0,0237	0,0271	0,0305	0,0339
16	8	401,92	301,44	S =	0,0080	0,0161	0,0241	0,0322	0,0402	0,0482	0,0563	0,0643	0,0723	0,0804
				T =	0,0060	0,0121	0,0181	0,0241	0,0301	0,0362	0,0422	0,0482	0,0543	0,0603
20	10	628,00	471,00	S =	0,0126	0,0251	0,0377	0,0502	0,0628	0,0754	0,0879	0,1005	0,1130	0,1256
				T =	0,0094	0,0188	0,0283	0,0377	0,0471	0,0565	0,0659	0,0754	0,0848	0,0942
25	12	981,25	755,17	S =	0,0196	0,0393	0,0589	0,0785	0,0981	0,1178	0,1374	0,1570	0,1766	0,1963
				T =	0,0151	0,0302	0,0453	0,0604	0,0755	0,0906	0,1057	0,1208	0,1359	0,1510
32	16	1607,68	1205,76	S =	0,0322	0,0643	0,0965	0,1286	0,1608	0,1929	0,2251	0,2572	0,2894	0,3215
				T =	0,0241	0,0482	0,0723	0,0965	0,1206	0,1447	0,1688	0,1929	0,2170	0,2412

Архангельск (8182)63-90-72
 Астана (7172)727-132
 Астрахань (8512)99-46-04
 Барнаул (3852)73-04-60
 Белгород (4722)40-23-64
 Брянск (4832)59-03-52
 Владивосток (423)249-28-31
 Волгоград (844)278-03-48
 Вологда (8172)26-41-59
 Воронеж (473)204-51-73
 Екатеринбург (343)384-55-89
 Иваново (4932)77-34-06

Ижевск (3412)26-03-58
 Иркутск (395)279-98-46
 Казань (843)206-01-48
 Калининград (4012)72-03-81
 Калуга (4842)92-23-67
 Кемерово (3842)65-04-62
 Киров (8332)68-02-04
 Краснодар (861)203-40-90
 Красноярск (391)204-63-61
 Курск (4712)77-13-04
 Липецк (4742)52-20-81
 Киргизия (996)312-96-26-47

Магнитогорск (3519)55-03-13
 Москва (495)268-04-70
 Мурманск (8152)59-64-93
 Набережные Челны (8552)20-53-41
 Нижний Новгород (831)429-08-12
 Новокузнецк (3843)20-46-81
 Новосибирск (383)227-86-73
 Омск (3812)21-46-40
 Орел (4862)44-53-42
 Оренбург (3532)37-68-04
 Пенза (8412)22-31-16
 Казахстан (772)734-952-31

Пермь (342)205-81-47
 Ростов-на-Дону (863)308-18-15
 Рязань (4912)46-61-64
 Самара (846)206-03-16
 Санкт-Петербург (812)309-46-40
 Саратов (845)249-38-78
 Севастополь (8692)22-31-93
 Симферополь (3652)67-13-56
 Смоленск (4812)29-41-54
 Сочи (862)225-72-31
 Ставрополь (8652)20-65-13
 Таджикистан (992)427-82-92-69

Сургут (3462)77-98-35
 Тверь (4822)63-31-35
 Томск (3822)98-41-53
 Тула (4872)74-02-29
 Тюмень (3452)66-21-18
 Ульяновск (8422)24-23-59
 Уфа (347)229-48-12
 Хабаровск (4212)92-98-04
 Челябинск (351)202-03-61
 Череповец (8202)49-02-64
 Ярославль (4852)69-52-93